

# SG0812

Shaft dia.(軸径)  $\phi 8$  Lead(リード) 12mm

C5

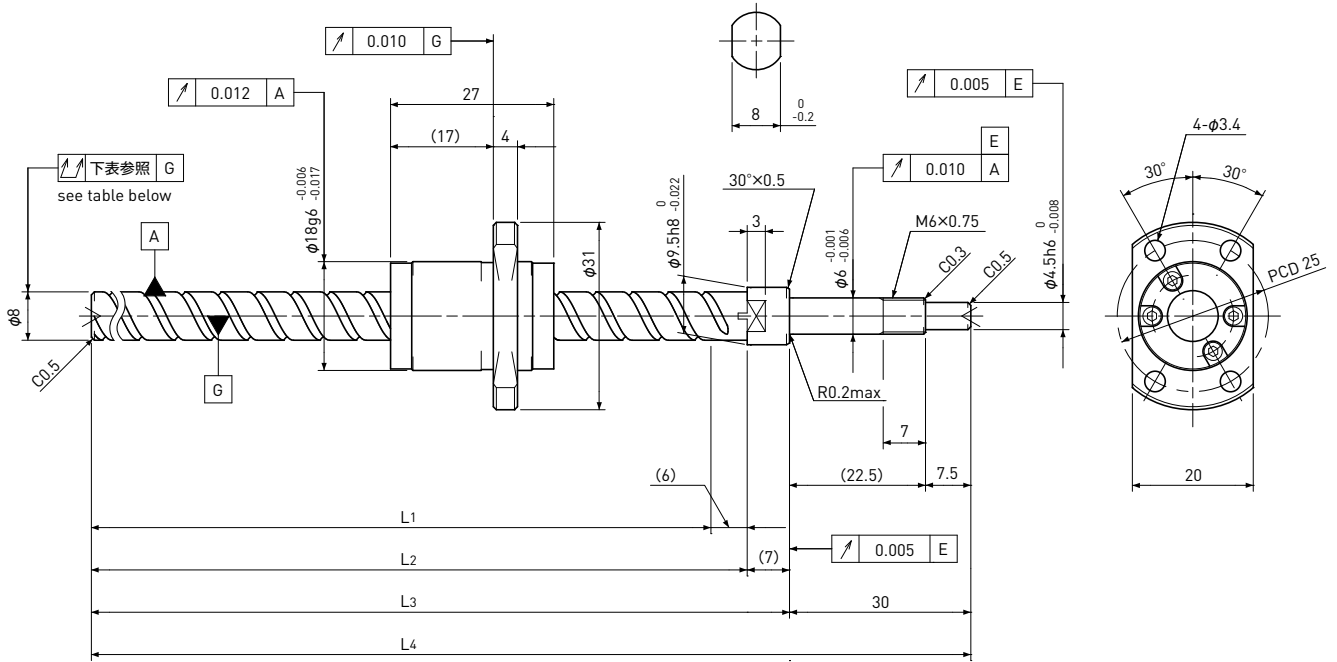

Unit(単位): mm

Ball Screw Specifications 諸元	
Ball size ボール径	$\phi 1.5875$
Number of thread 条数	2
Thread direction 巻方向	Right 右
Shaft root dia. ねじ軸谷径	$\phi 6.7$
Number of circuit 循環数	$1.6 \times 2$
Shaft, Nut material 軸、ナット材質	SCM415H
Surface hardness ねじ部表面硬度	HRC58~62 (Thread area)
Anti-rust treatment 防錆処理	Anti-rust oil 防錆油

Supported-side end-journal profile 支持側端末加工形状

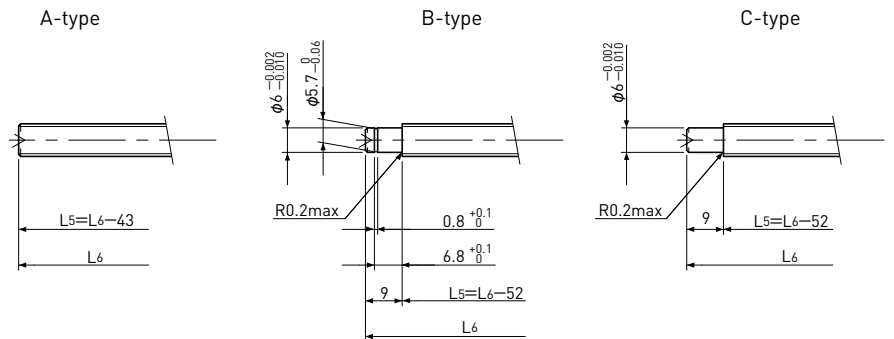

L5: Thread length after end-journal machining. 追加加工後のねじ部長さ  
L6: Total length after end-journal machining. 追加加工後全長

Support-unit Recommendation 推奨サポートユニット	Supported-side 支持側	Fixed-side 固定側
	MSU-6CS/6GS	MSU-6C/6G

D-type: Other than the above. 上記以外の形状

Unit(単位): mm

Ball Screw Model ボールねじ型番	Travel ストローク	Grade 精度	Shaft length ねじ軸長さ				Lead accuracy リード精度		Total Run-out 全振れ	Axial play 軸方向すきま	Preload Torque 予圧トルク Nm	Basic Load Rating 基本定格荷重 N	
			L1	L2	L3	L4	Travel deviation 代表移動量誤差 $e_p$	Variation 変動 $V_u$				Dynamic 動定格荷重 $C_a$	Static 静定格荷重 $C_oa$
SG0812-097R140C5	70	C5	97	103	110	140	$\pm 0.018$	0.018	0.050	~0.005	—	2200	4000
SG0812-207R250C5	180	C5	207	213	220	250	$\pm 0.023$	0.018	0.065				

Note) Please refer to page A206 for order code of end-journal machining. 注)追加加工の呼び番号指定はページA206をご参照ください。