

SG1005

Shaft dia.(軸径) $\phi 10$ Lead(リード) 5mm

C3&C5

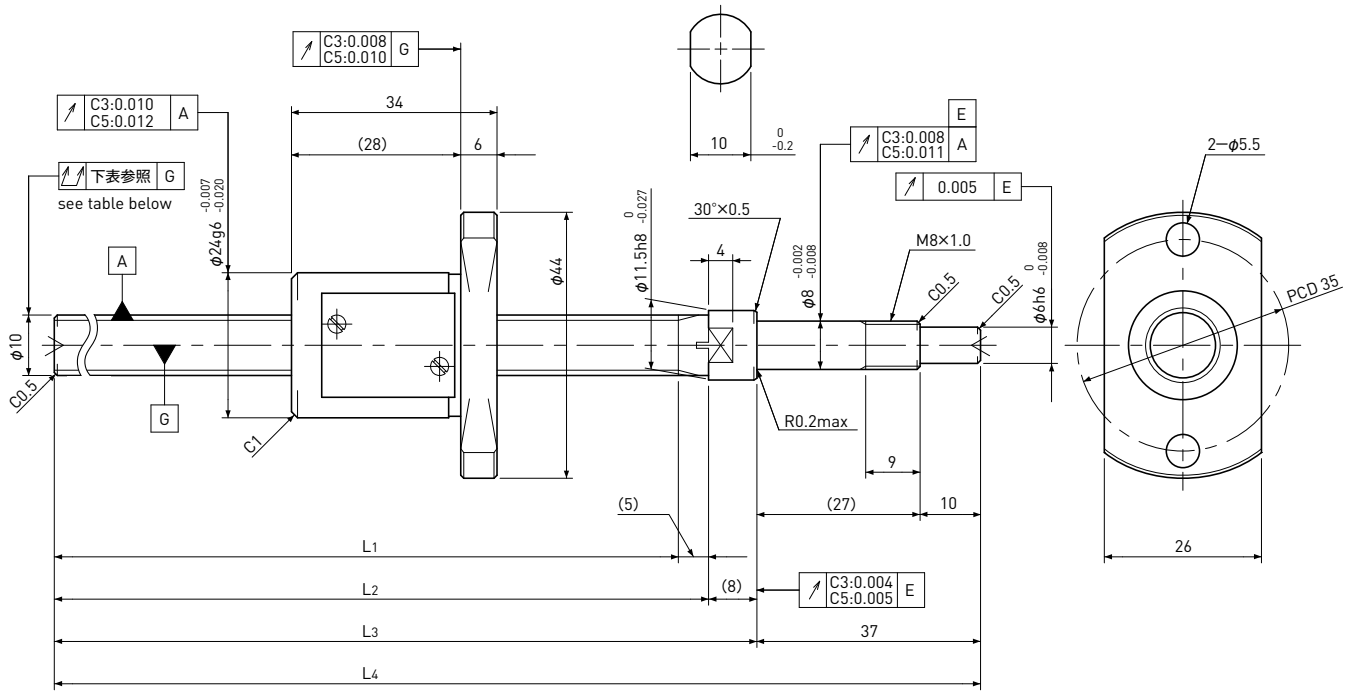

Unit(単位): mm

Ball Screw Specifications 諸元	
Ball size ボール径	$\phi 2.0$
Number of thread 条数	1
Thread direction 巻方向	Right 右
Shaft root dia. ねじ軸谷径	$\phi 8.2$
Number of circuit 循環数	2.7×1
Shaft, Nut material 軸、ナット材質	SCM415H
Surface hardness ねじ部表面硬度	HRC58~62 (Thread area)
Anti-rust treatment 防錆処理	Anti-rust oil 防錆油

Supported-side end-journal profile 支持側端末加工形状

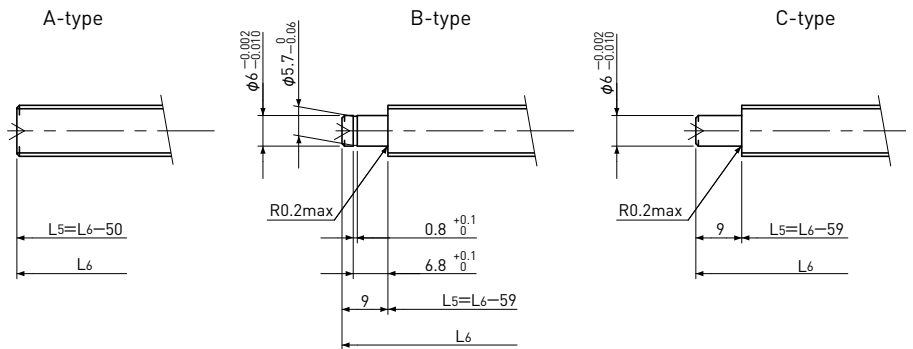

L_5 : Thread length after end-journal machining. 追加加工後のねじ部長さ
 L_6 : Total length after end-journal machining. 追加加工後全長

Support-unit Recommendation 推奨サポートユニット	Supported-side 支持側	Fixed-side 固定側
	MSU-8CS/8GS	MSU-8C/8G

D-type: Other than the above. 上記以外の形状

Unit(単位): mm

Ball Screw Model ボールねじ型番	Travel ストローク	Grade 精度	Shaft length ねじ軸長さ				Lead accuracy リード精度		Total Run-out 全振れ	Axial play 軸方向すきま	Preload Torque 予圧トルク Nm	Basic Load Rating 基本定格荷重 N	
			L_1	L_2	L_3	L_4	Travel deviation 代表移動量誤差 e_p	Variation 変動 V_u				Dynamic 動定格荷重 C_a	Static 静定格荷重 C_oa
SG1005-110R160C3	75	C3	110	115	123	160	± 0.010	0.008	0.035	0 Spacer Ball スペーサーボール (1:1)	0.005~ 0.040	1800	2600
SG1005-260R310C3	225	C3	260	265	273	310	± 0.012	0.008	0.040				
SG1005-110R160C5	75	C5	110	115	123	160	± 0.020	0.018	0.040	~0.005	—	3000	5200
SG1005-260R310C5	225	C5	260	265	273	310	± 0.023	0.018	0.055				

Note) Please refer to page A206 for order code of end-journal machining. 注)追加加工の呼び番号指定はページA206をご参照ください。