

SRT0610 | Shaft dia.(軸径) $\phi 6$ Lead(リード) 10mm | Ct7&Ct10

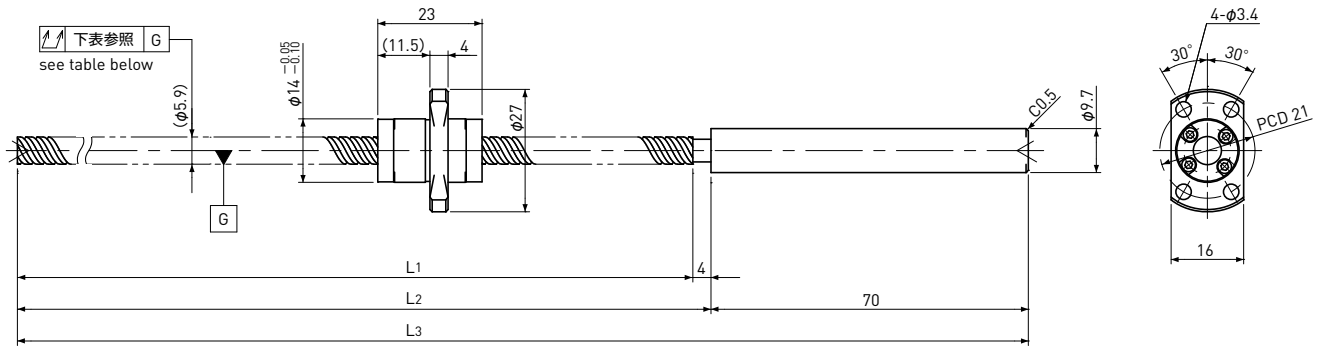

Unit(単位): mm

Ball Screw Specifications 諸元		
Ball size ボール径	$\phi 1.2$	
Number of thread 条数	2	
Thread direction 巻方向	Right 右	
Shaft root dia. ねじ軸谷径	$\phi 5.0$	
Number of circuit 循環数	1.2×2	
Material 材質	Shaft 軸	SCM415H+SUS303
	Nut ナット	SCM415H
Surface hardness ねじ部表面硬度	HRC58~ (Thread area)	
Anti-rust treatment 防錆処理	Anti-rust oil 防錆油	

End-journal profile 端末加工形状 Supported-side 支持側

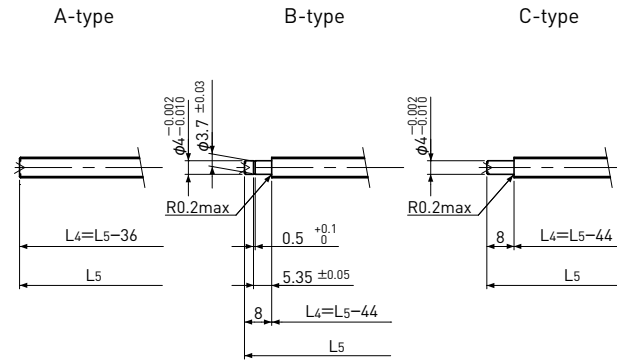

L4: Thread length after end-journal machining. 追加工後のねじ部長さ
L5: Total length after end-journal machining. 追加工後全長

Fixed-side 固定側

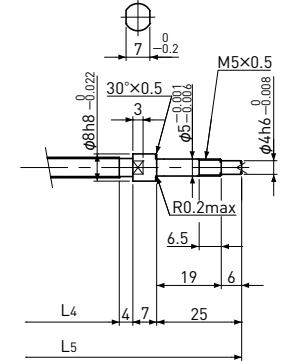

Support-unit Recommendation 推奨サポートユニット	Supported-side 支持側	Fixed-side 固定側
	MSU-5CS/5GS	MSU-5C/5G

D-type: Other than the above. 上記以外の形状

Unit(単位): mm

Ball Screw Model ボールねじ型番	Travel ストローク	Grade 精度	Shaft length ねじ軸長さ			Lead accuracy リード精度		Total Run-out 全振れ	Axial play 軸方向すきま	Preload Torque 予圧トルク Nm	Basic Load Rating 基本定格荷重 N	
			L1	L2	L3	Travel deviation 代表移動量誤差 e _p	Variation 変動 V ₃₀₀				Dynamic 動定格荷重 Ca	Static 静定格荷重 Coa
SRT0610-146R220C7	120	Ct7	146	150	220	±0.02	—	0.080	~0.020	—	950	1600
SRT0610-261R335C7	235	Ct7	261	265	335	±0.04	—	0.120				
SRT0610-146R220C10	120	Ct10	146	150	220	±0.10	—	0.160	~0.050	—	950	1600
SRT0610-261R335C10	235	Ct10	261	265	335	±0.18	—	0.240				

Note) Please refer to page A287 for order code of end-journal machining. 注) 追加工の呼び番号指定方法はページA287をご参照ください。