

SRT0812 | Shaft dia.(軸径) $\phi 8$ Lead(リード) 12mm | Ct7&Ct10

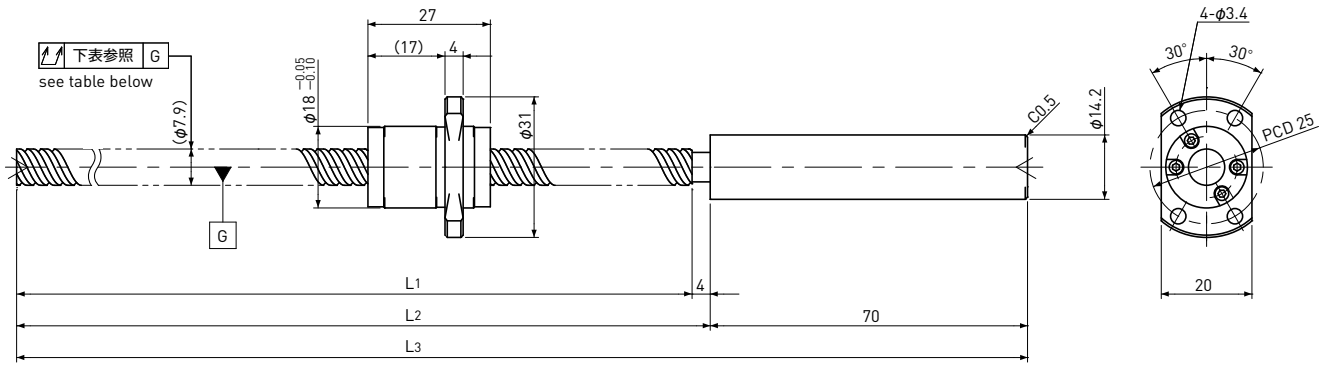

Unit(単位): mm

Ball Screw Specifications 諸元		
Ball size ボール径		$\phi 1.5875$
Number of thread 条数		2
Thread direction 巻方向		Right 右
Shaft root dia. ねじ軸谷径		$\phi 6.7$
Number of circuit 循環数		1.6×2
Material 材質	Shaft 軸	SCM415H+SUS303
	Nut ナット	SCM415H
Surface hardness ねじ部表面硬度		HRC58~(Thread area)
Anti-rust treatment 防錆処理		Anti-rust oil 防錆油

End-journal profile 端末加工形状 Supported-side 支持側

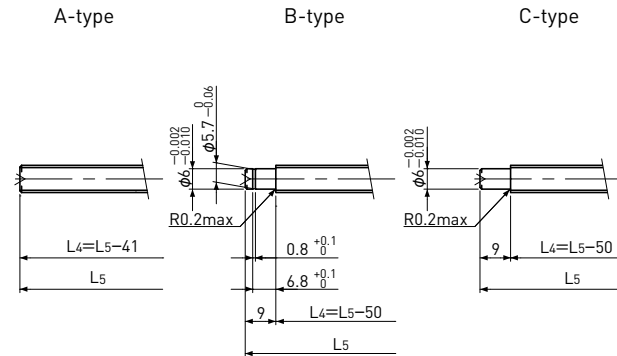

L4: Thread length after end-journal machining. 追加加工後のねじ部長さ
L5: Total length after end-journal machining. 追加加工後全長

Fixed-side 固定側

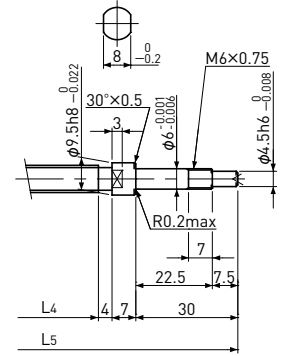

Support-unit Recommendation 推奨サポートユニット	Supported-side 支持側	Fixed-side 固定側
	MSU-6CS/6GS	MSU-6C/6G

D-type: Other than the above. 上記以外の形状

Unit(単位): mm

Ball Screw Model ボールねじ型番	Travel ストローク	Grade 精度	Shaft length ねじ軸長さ			Lead accuracy リード精度		Total Run-out 全振れ	Axial play 軸方向すきま	Preload Torque 予圧トルク Nm	Basic Load Rating 基本定格荷重 N	
			L1	L2	L3	Travel deviation 代表移動量誤差 e_p	Variation 変動 V_{300}				Dynamic 動定格荷重 Ca	Static 静定格荷重 Coa
SRT0812-196R270C7	165	Ct7	196	200	270	± 0.03	—	0.080	~0.020	—	2200	4000
SRT0812-356R430C7	325	Ct7	356	360	430	± 0.06	0.05	0.120				
SRT0812-196R270C10	165	Ct10	196	200	270	± 0.13	—	0.160	~0.050	—	2200	4000
SRT0812-356R430C10	325	Ct10	356	360	430	± 0.24	0.21	0.240				

Note) Please refer to page A287 for order code of end-journal machining. 注) 追加加工の呼び番号指定方法はページA287をご参照ください。