

# PSRT0401 | Shaft dia. (軸径) $\phi 4$ Lead (リード) 1mm | C5

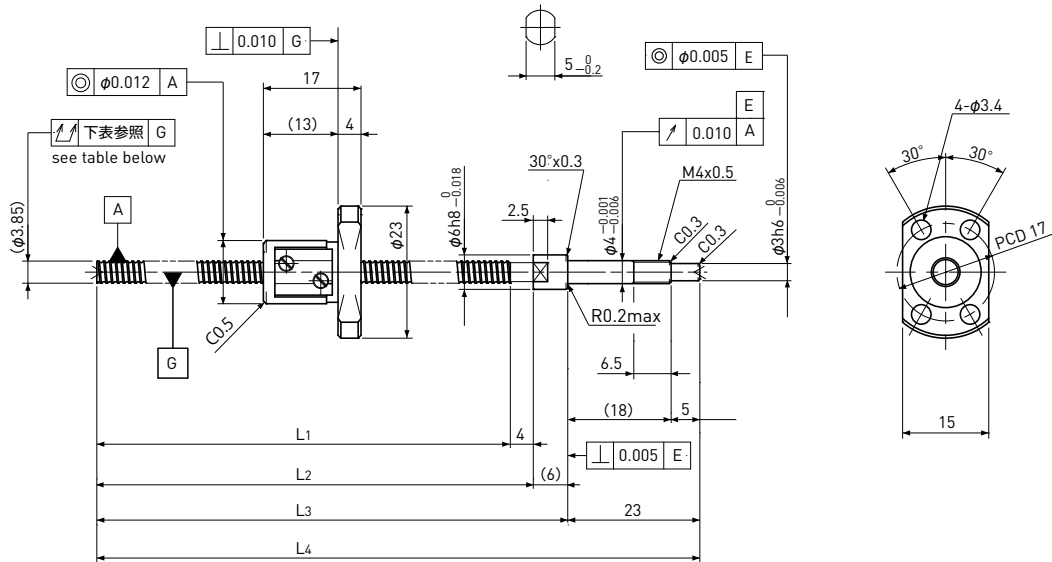

Unit (単位): mm

Ball Screw Specifications 諸元	
Ball size ボール径	$\phi 0.8$
Number of thread 条数	1
Thread direction 巻方向	Right 右
Shaft root dia. ねじ軸谷径	$\phi 3.3$
Number of circuit 循環数	$3.7 \times 1$
Material 材質	Shaft 軸 S55C+SUS303
	Nut ナット SCM415H
Surface hardness ねじ部表面硬度	HRC58~ (Thread area)
Lubrication 出荷時封入剤	KSS Original Grease MSG No.2

## Supported-side end-journal profile 支持側端末加工形状

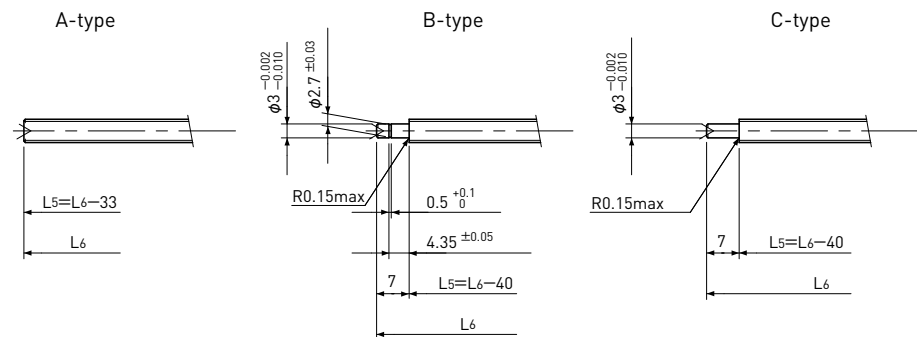

$L_5$ : Thread length after end-journal machining. 追加加工後のねじ部長さ  
 $L_6$ : Total length after end-journal machining. 追加加工後全長

Support-unit Recommendation 推奨サポートユニット	Supported-side 支持側	Fixed-side 固定側
	MSU-4CS/4GS, SUP03-S	MSU-4C/4G, EK4

D-type: Other than the above. 上記以外の形状

Unit (単位): mm

Ball Screw Model ボールねじ型番	Travel ストローク	Shaft length ねじ軸長さ				Travel deviation 代表移動量誤差 $e_p$	Total Run-out 全振れ $\nearrow$	Axial play 軸方向すきま	Basic Load Rating 基本定格荷重 N	
		$L_1$	$L_2$	$L_3$	$L_4$				Dynamic 動定格荷重 $C_a$	Static 静定格荷重 $C_{0a}$
PSRT0401-72R105C5	50	72	76	82	105	$\pm 0.018$	0.035	$\sim 0.005$	560	790

Note) Please refer to page A-321 for order code of end-journal machining. 注)追加加工の呼び番号指定方法は、ページA-321をご参照ください。