

PSRT0802

Shaft dia. (軸径) $\phi 8$ Lead (リード) 2mm

C5

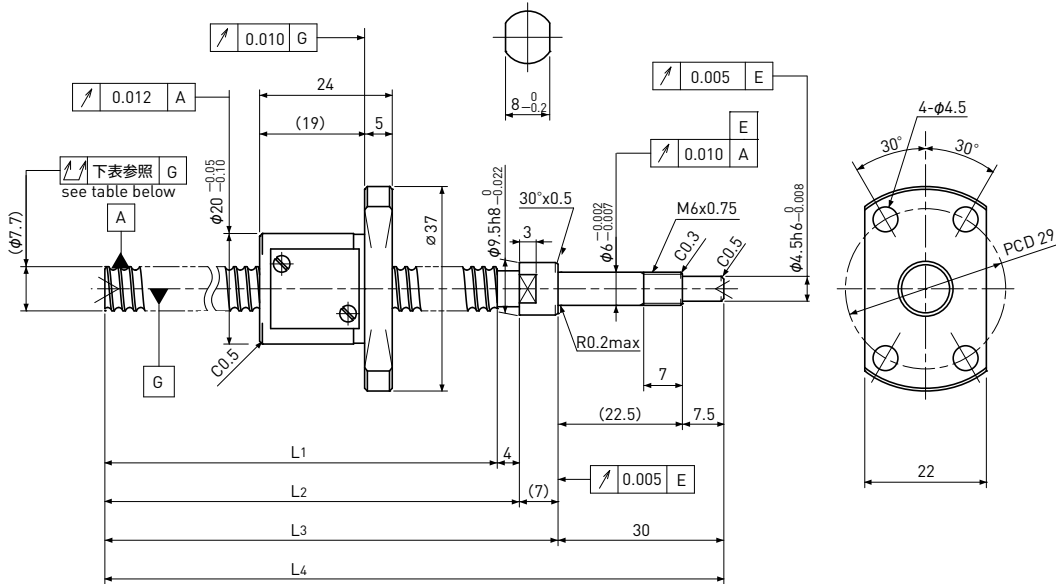

Unit (単位): mm

Ball Screw Specifications 諸元		
Ball size ボール径		$\phi 1.5875$
Number of thread 条数		1
Thread direction 巻方向		Right 右
Shaft root dia. ねじ軸谷径		$\phi 6.6$
Number of circuit 循環数		3.7×1
Material 材質	Shaft 軸	S55C+SUS303
	Nut ナット	SCM415H
Surface hardness ねじ部表面硬度		HRC58~ (Thread area)
Lubrication 出荷時封入剤		KSS Original Grease MSG No.2

Supported-side end-journal profile 支持側端末加工形状

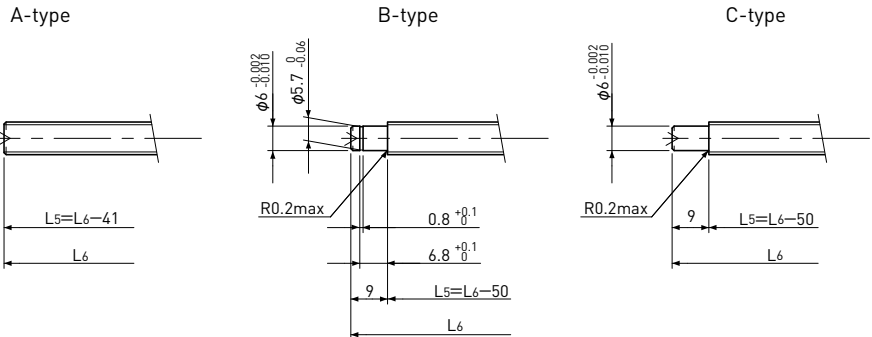

L5: Thread length after end-journal machining. 追加後のねじ部長さ
L6: Total length after end-journal machining. 追加後全長

Support-unit Recommendation 推奨サポートユニット	Supported-side 支持側	Fixed-side 固定側
	MSU-6CS/6GS	MSU-6C/6G

D-type : Other than the above 上記以外の形状

Unit (単位): mm

Ball Screw Model ボールねじ型番	Travel ストローク	Shaft length ねじ軸長さ				Travel deviation 代表移動量誤差 e_p	Total Run-out 全振れ \nearrow	Axial play 軸方向すきま	Basic Load Rating 基本定格荷重 N	
		L1	L2	L3	L4				Dynamic 動定格荷重 C_a	Static 静定格荷重 C_{0a}
PSRT0802-169R210C5	140	169	173	180	210	± 0.020	0.065	~ 0.005	2400	4100

Note) Please refer to page A321 for order code of end-journal machining. 注)追加加工の呼び番号指定方法は、ページA321をご参照ください。