

SR0820

Shaft dia. (軸径) $\phi 8$ Lead (リード) 20mm

Ct7&Ct10

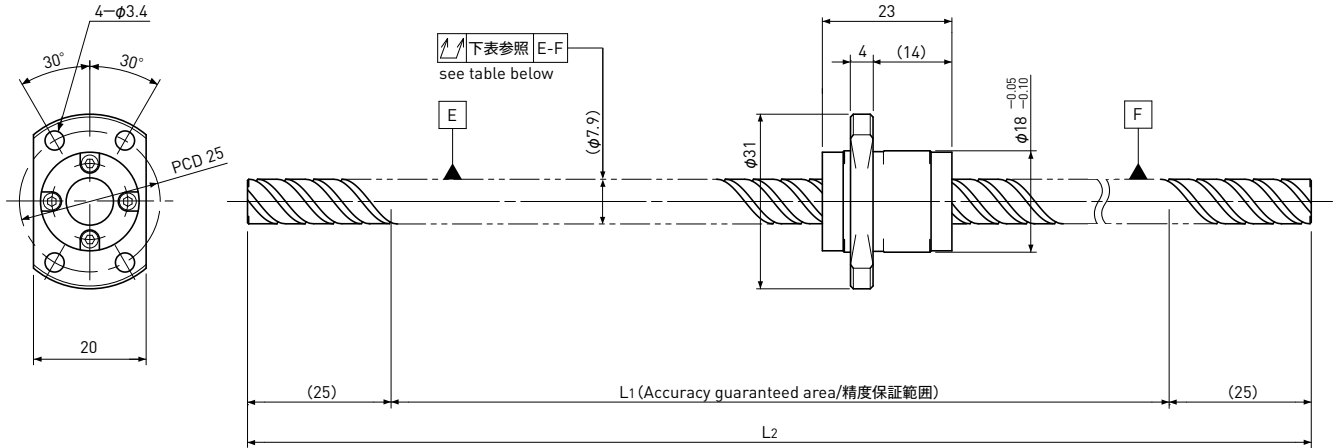

Unit (単位) : mm

Ball Screw Specifications 諸元	
Ball size ボール径	$\phi 1.5875$
Number of thread 条数	4
Thread direction 巻方向	Right 右
Shaft root dia. ねじ軸谷径	$\phi 6.7$
Number of circuit 循環数	0.7×4
Shaft, Nut material 軸、ナット材質	SCM415H
Surface hardness ねじ部表面硬度	HRC58~62 (Thread area)
Anti-rust treatment 防錆処理	Anti-rust oil 防錆油

Unit (単位) : mm

Ball Screw Model ボールねじ型番	Travel ストローク	Grade 精度	Shaft length ねじ軸長さ		Lead accuracy リード精度		Total Run-out 全振れ	Axial play 軸方向すきま	Preload Torque 予圧トルク Nm	Basic Load Rating 基本定格荷重 N	
			L ₁	L ₂	Travel deviation 代表移動量誤差 e _p	Variation 変動 V ₃₀₀				Dynamic 動定格荷重 Ca	Static 静定格荷重 Coa
SR0820-400R400C7	325	Ct7	350	400	± 0.060	0.052	0.120	~0.020	—	1650	3150
SR0820-400R400C10	325	Ct10	350	400	± 0.245	0.210	0.240	~0.050			

Note) Please designate end-journal profile with your sketch. 注)軸端の追加加工は図面とともにご指示ください。